

Wide input voltage Non-isolated and Regulated  
Single Output

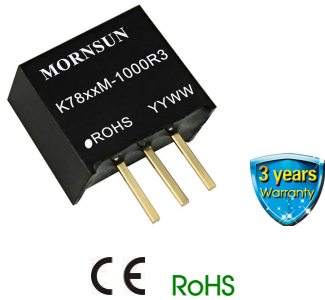

## FEATURES

- High efficiency up to 96%
- No-load input current as low as 0.3mA
- Operating ambient temperature range -40 °C to +85 °C
- Support the negative output
- Output short-circuit protection
- Pin-out compatible with LM78XX linear regulators
- EN62368 Approval

K78xxM-1000R3 series are high efficiency switching regulators and ideal substitutes for LM78xx series three-terminal linear regulators. The converters feature high efficiency, low loss, short circuit protection, positive or negative output voltage, and there is no need for a heat sink. These products are widely used in applications such as industrial control, instrumentation and electric power.

## Selection Guide

Certification	Part No.	Input Voltage (VDC)*		Output		Full Load Efficiency (%) Vin Min. / Vin Max.	Max. Capacitive Load (µF)
		Nominal (Range)	Voltage (VDC)	Current (mA) Max.			
CE	K7803M-1000R3	24 (6-36)	3.3	1000	90/80	680	
		24 (8-36)	5	1000	93/85	680	
	K7805M-1000R3	12 (8-27)	-5	-500	85/81	330	
		24 (13-36)	9	1000	94/89	680	
	K7812M-1000R3	24 (16-36)	12	1000	95/92	680	
		12 (8-20)	-12	-300	88/87	330	
	K7815M-1000R3	24 (20-36)	15	1000	96/93	680	
		12 (8-18)	-15	-300	87/88	330	

\*Note: For input voltages exceeding 30 VDC, an input capacitor of 22µF/50V is required.

## Input Specifications

Item	Operating Conditions	Min.	Typ.	Max.	Unit
No-load Input Current	Positive output	--	0.3	1	mA
	Negative output	--	1	4	
Reverse Polarity at Input		Avoid / Not protected			
Input Filter		Capacitance filter			

## Output Specifications

Item	Operating Conditions	Min.	Typ.	Max.	Unit	
Voltage Accuracy	Full load, input voltage range	K7803M-1000R3	--	±2	±4	
		Others	--	±1.5	±3	
Linear Regulation	Full load, input voltage range	--	±0.2	±0.4	%	
Load Regulation	Nominal input, 10% -100% load	Positive output	--	±0.4		±0.6
		Negative output	--	±0.4	±0.8	
Ripple & Noise*	20MHz bandwidth, nominal input, 20% -100% load	--	25	75	mVp-p	

Temperature Coefficient	100% load	--	--	±0.03	%/°C
Transient Response Deviation	Nominal input voltage, 25% load step change	--	±60	±200	mV
Transient Recovery Time		--	--	1	ms
Short-circuit Protection	Nominal input	Continuous, self-recovery			

\*Note:  
 1. The "parallel cable" method is used for ripple and noise test, please refer to DC-DC Converter Application Notes for specific information;  
 2. With light loads at or below 20%, Ripple and Noise for 3.3V/ 5V output parts increases to 100mVp-p max., and for 9V/ 12V/ 15V output parts to 2%Vo max.

### General Specifications

Item	Operating Conditions	Min.	Typ.	Max.	Unit
Operating Temperature	See Fig.1	-40	--	85	°C
Storage Temperature		-55	--	125	
Pin Soldering Resistance Temperature	Soldering spot is 1.5mm away from case for 10 seconds	--	--	260	
Storage Humidity	Non-condensing	--	--	95	%RH
Switching Frequency	Full load, nominal input	--	520	--	KHz
MTBF	MIL-HDBK-217F@25°C	2000	--	--	K hours

Note:  
 When Vin >30V, for positive output of 9V/12V/15V, product start to derating from temperature ≥ 55°C and derating to 40%Io if the temperature is 85°C.

### Mechanical Specifications

Case Material	Black plastic; flame-retardant and heat-resistant (UL94 V-0)
Dimensions	11.60 x 8.00 x 10.40 mm
Weight	1.9g (Typ.)
Cooling Method	Free air convection

### Electromagnetic Compatibility (EMC)

Emissions	CE	CISPR32/EN55032	CLASS B (see Fig. 4-② for recommended circuit)
	RE	CISPR32/EN55032	CLASS B (see Fig. 4-② for recommended circuit)
Immunity	ESD	IEC/EN 61000-4-2	Contact ±4KV perf. Criteria B
	RS	IEC/EN 61000-4-3	10V/m perf. Criteria A
	EFT	IEC/EN 61000-4-4	±1KV (see Fig. 4-① for recommended circuit) perf. Criteria B
	Surge	IEC/EN 61000-4-5	line to line ±1KV(see Fig. 4-① for recommended circuit) perf. Criteria B
	CS	IEC/EN 61000-4-6	3Vr.m.s perf. Criteria A

### Typical Characteristic Curves

3.3V/5V output

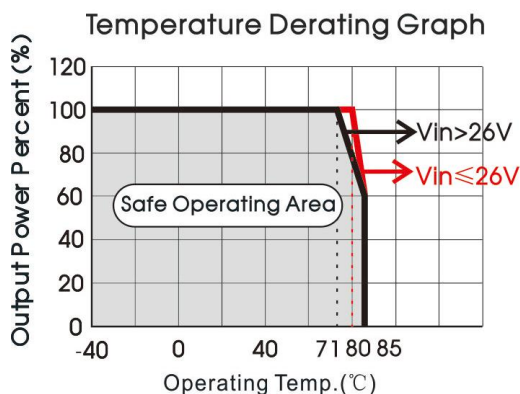

9V/12V/15V output

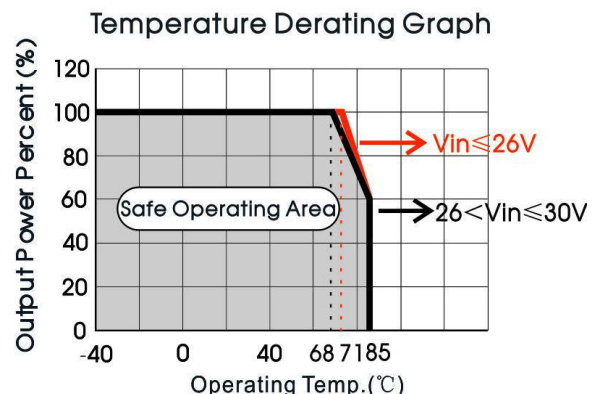

Negative output

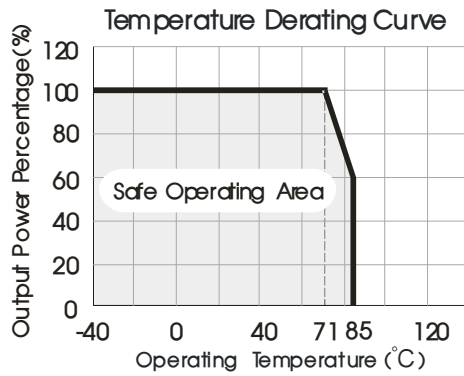
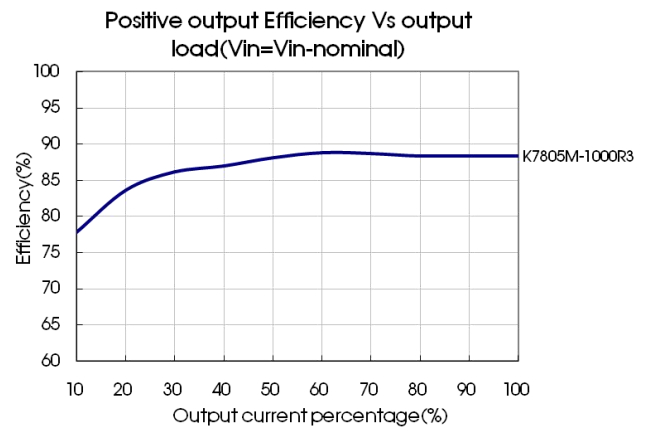
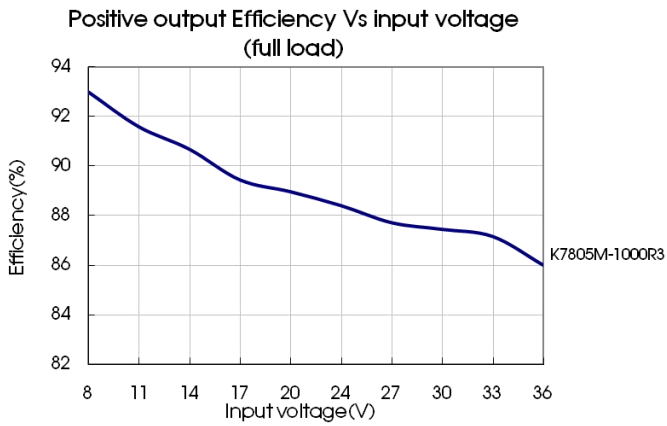

Fig. 1



## Design Reference

### 1. Typical application

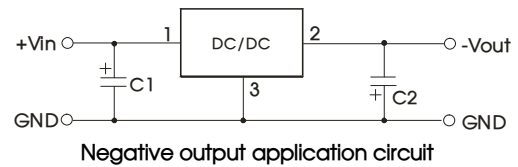
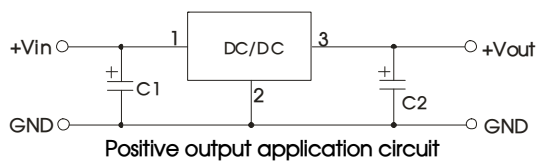

Fig. 2 Typical application circuit

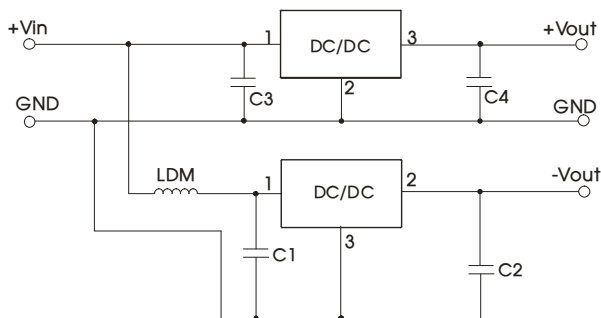

Fig. 3 Positive and Negative output application circuit

Note:

1. The required capacitors C1 and C2 (C3 and C4) must be connected close as possible to the terminals of the module.
2. Refer to Table 1 for C1 and C2 (C3 and C4) capacitor values. For certain applications, increased values for C2 and C4 and/or tantalum or low ESR electrolytic capacitors may also be used instead.
4. When using configurations as shown in figure 3, we recommended to add an inductor (LDM) with a value of up to 10μH which helps reducing mutual interference.
5. Converter cannot be used for hot swap and with output in parallel.

### 2. EMC Compliance circuit

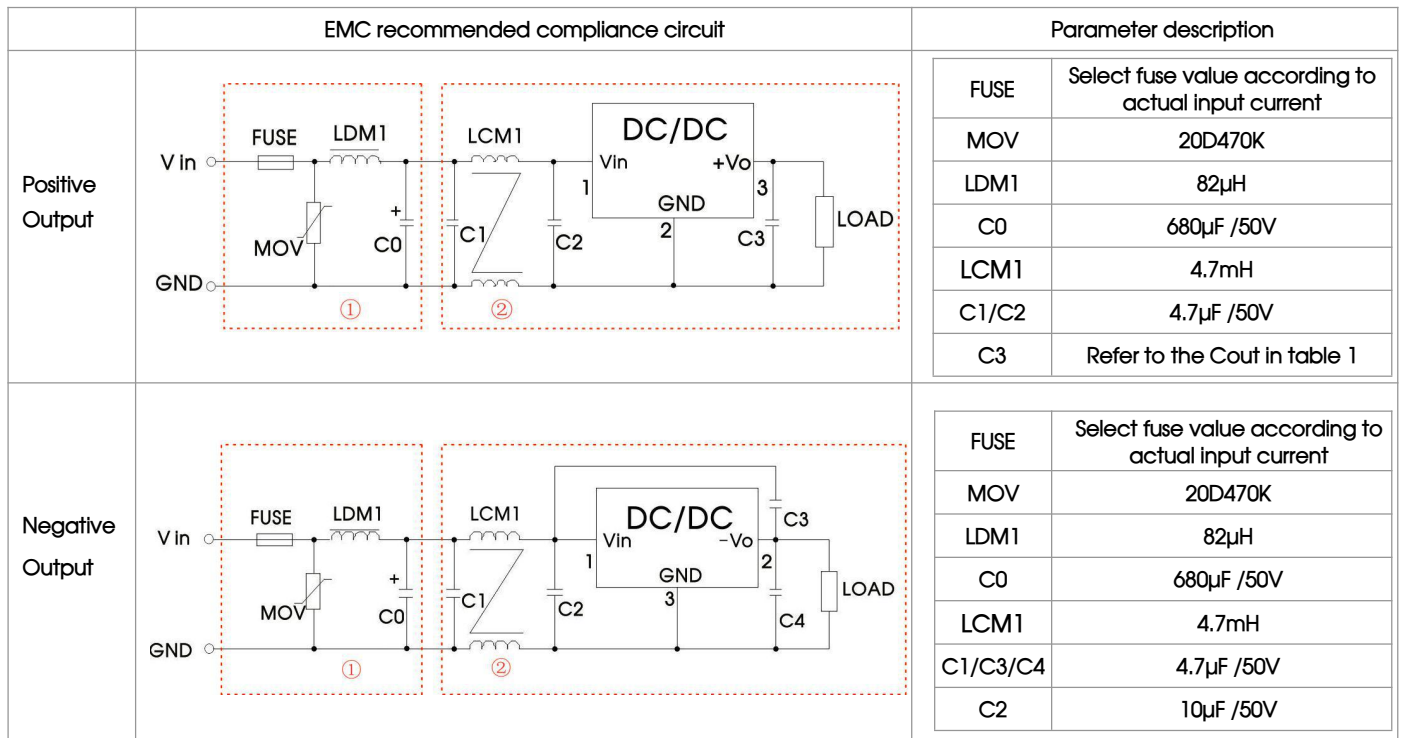
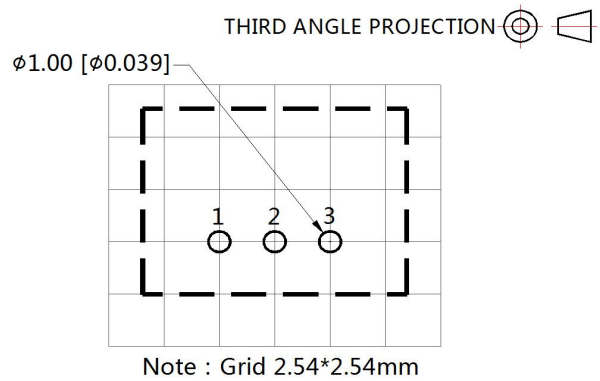
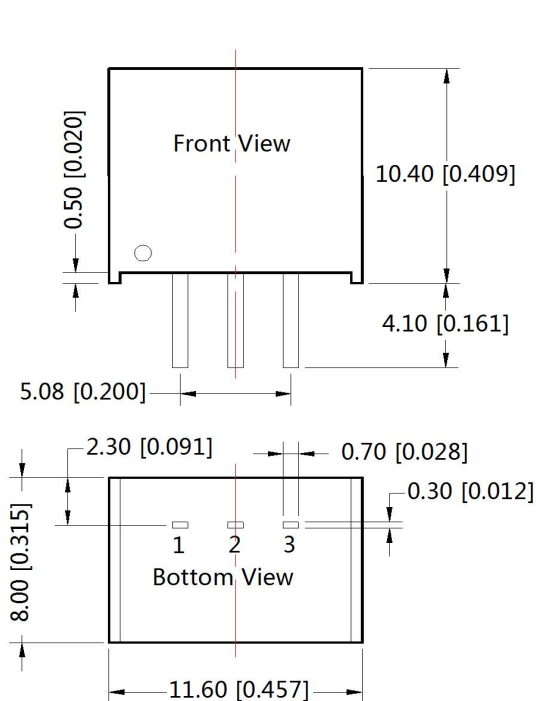

Fig. 4 Recommended compliance circuit

Note: Part ① in Fig. 4 shows EMS compliance filter and part ② filter for EMI compliance; depending on requirement both filters ① and ② can be used in series as shown.

3. For additional information please refer to DC-DC converter application notes on [www.mornsun-power.com](http://www.mornsun-power.com)

## Dimensions and Recommended Layout



Pin-Out		
Pin	Positive Output	Negative Output
1	Vin	Vin
2	GND	-Vo
3	+Vo	GND

Note:  
 Unit: mm[inch]  
 Pin section tolerances: ±0.10[±0.004]  
 General tolerances: ±0.50[±0.020]

Notes:

1. For additional information on Product Packaging please refer to [www.mornsun-power.com](http://www.mornsun-power.com). Packaging bag number: 58200003.
2. The specified maximum capacitive load is tested under full load condition and over the input voltage range;
3. All parameters in this datasheet were measured under following conditions:  $T_a=25^{\circ}\text{C}$ , relative humidity <75%RH, nominal input voltage and rated output load (unless otherwise specified);
4. All index testing methods in this datatable are based on our Company's corporate standards;
5. The performance indexes of the product models listed in this manual are as above, but some indexes of non-standard model products will exceed the above-mentioned requirements, and please directly contact with our technician for specific information;
6. Products are related to laws and regulations: see "Features" and "EMC";
7. Our products shall be classified according to ISO14001 and related environmental laws and regulations, and shall be handled by qualified units.

## MORNSUN Guangzhou Science & Technology Co., Ltd.

Address: No. 5, Kehui St. 1, Kehui Development Center, Science Ave., Guangzhou Science City, Luogang District, Guangzhou, P. R. China  
Tel: 86-20-38601850 Fax: 86-20-38601272 E-mail: [sales@mornsun.cn](mailto:sales@mornsun.cn) [www.mornsun-power.com](http://www.mornsun-power.com)