

# MAF150 SERIES

2 X 4 Inch AC-DC POWER SUPPLIES

UNIVERSAL INPUT RANGE  
 UP TO 150Watts



## FEATURES

- LOW STANDBY POWER CONSUMPTION UNDER 0.3 WATT
- WIDE INPUT VOLTAGE RANGE 85 TO 264VAC, 47 TO 63HZ
- ACTIVE POWER FACTOR CORRECTION
- BUILT-IN EMI FILTER
- OUTPUT VOLTAGE ADJUSTABLE
- OPEN FRAME DIMENSIONS 2.00 X 4.00 X 1.16 INCH
- 4000VAC INPUT TO OUTPUT 2MOPP INSULATION
- PROTECTION TYPE CLASS I AND CLASS II
- LOW LEAKAGE CURRENT UNDER 100µA
- OPERATING ALTITUDE 5000M
- 5 YEAR WARRANTY
- ANSI/AAMI ES60601-1, EN60601-1, & IEC60601-1 3<sup>rd</sup> EDITION SAFETY APPROVALS
- CE MARKED
- COMPLIANT TO RoHS II & REACH

## APPLICATIONS

- MEDICAL EQUIPMENT

4000VAC ISOLATION	OCP	SCP	OVP	LOW STANDBY POWER
-------------------	-----	-----	-----	-------------------

## TECHNICAL SPECIFICATION

All specifications are typical at 230VAC input, full load and 25°C otherwise noted

Model Number	Input Range	Output Voltage	Output Current @ Forced air cooling 50°C Ta with 10CFM	Output Current @ Natural convection 50°C Ta	Efficiency
	VAC	VDC	A	A	
MAF150US12	85 ~ 264	12	12.50	8.33	91
MAF150US15	85 ~ 264	15	10.00	7.33	92
MAF150US24	85 ~ 264	24	6.25	4.58	92
MAF150US28	85 ~ 264	28	5.36	3.92	92
MAF150US36	85 ~ 264	36	4.17	3.05	92
MAF150US48	85 ~ 264	48	3.13	2.08	92

## PART NUMBER STRUCTURE

M	A	F	150	U	S	12	□	-	□
Application	Package Code	Dimension Code	Output Power (W)	Input Voltage (VAC)	Output Quantity	Output Voltage (VDC)	Protection Type		Option
Medical Application	A: Open type U: U chassis type E: Enclosed type D: Din rail (E type only)			U: Universal 85 ~ 264VAC	S: Single	12: 12V 15: 15V 24: 24V 28: 28V 36: 36V 48: 48V	No suffix: CLASS I B: CLASS II		F: External FAN (E type only)

## INPUT SPECIFICATIONS

Parameter	Conditions	Min.	Typ.	Max.	Unit
Operating input voltage range	AC input	85		264	VAC
	DC input	120		370	VDC
Input frequency	AC input	47		63	Hz
Input current	115VAC and Full Load			1.7	A
	230VAC and Full Load			0.8	
No load input power	230VAC			0.3	Watts
	230VAC MEF -F		0.6		
Leakage current	264VAC			100	μA
Power Factor		0.95			
Start up time				1000	ms
Rise time			20		ms
Hold up time	115VAC and Full Load	16			ms
Input inrush current	230VAC			60	A
Input protection	Internal fuse in line and neutral			T3.15A/250VAC	

## OUTPUT SPECIFICATIONS

Parameter	Conditions	Min.	Typ.	Max.	Unit
Output power	Forced air cooling with 10CFM			150	Watts
	Natural convection for 15Vout, 24Vout, 28Vout, 36Vout			110	
	Natural convection for 12Vout, 48Vout			100	
Initial set voltage accuracy	230VAC and Full Load	-1.0		+1.0	%
Line regulation	Low Line to High Line at Full Load	-0.2		+0.2	%
Load regulation	No Load to Full Load	-0.5		+0.5	%
	10% Load to 90% Load	-0.4		+0.4	
Voltage adjustability		-10		+10	%
Minimum load			0		%
Ripple and noise	Measured by 20MHz bandwidth				mVp-p
	With a 1μF/25V 1206 X7R MLCC	12Vout	120		
	With a 1μF/25V 1206 X7R MLCC	15Vout	150		
	With a 1μF/50V 1206 X7R MLCC	24Vout	220		
	With a 1μF/50V 1206 X7R MLCC	28Vout	220		
	With a 1μF/50V 1206 X7R MLCC	36Vout	250		
With a 0.1μF/100V 1206 X7R MLCC	48Vout	250			
Temperature coefficient		-0.02		+0.02	%/°C
Transient response	Load step form 50 ~ 75% change at 2.5A/μs	Peak deviation		3	% Vout
		Recovery time		500	μs
Over voltage protection	% of Vout(nom); Latch mode	115		135	%
Over load protection	% of Iout rated; Hiccup mode	115		150	%
Short circuit protection				Continuous, automatic recovery	
Fan power supply				12V at 500mA	

## GENERAL SPECIFICATIONS

Parameter	Conditions	Min.	Typ.	Max.	Unit
Isolation voltage	1 minute (2MOPP insulation)	Input to Output	4000		VAC
		Input (Output) to F.G.	1500		
Isolation resistance	500VDC	0.1			GΩ
Switching frequency			60		kHz
Safety approvals				ANSI/AAMI ES60601-1 EN60601-1 IEC60601-1	
Weight		MAF		187g	(6.60oz)
		MUF		235g	(8.29oz)
		MEF		256g	(9.03oz)
		MDF		278g	(9.81oz)
MTBF	MIL-HDBK-217F Ta=25°C, Full load			7.861 x 10 <sup>5</sup> hrs	

## ENVIRONMENTAL SPECIFICATIONS

Parameter	Conditions	Min.	Typ.	Max.	Unit
Operating ambient temperature	Forced air cooling: 150W with 10CFM	-25		+80	°C
	Natural convection: 100 ~ 110W	-25		+80	
Storage temperature range		-40		+85	°C
Operating altitude				5000	m
Thermal shock				MIL-STD-810F	
Shock				IEC68-2-27	
Vibration				IEC68-2-6	
Relative humidity	Non-condensing			5% to 95% RH	

**EMC SPECIFICATIONS**

Parameter	Conditions			Level
EMI	EN55011, EN55022 and FCC Part 18			Conducted Class B Radiated Class A
Harmonic currents	EN61000-3-2	Full Load		Class A and D
Voltage flicker	EN61000-3-3			
ESD	EN61000-4-2	Air ± 8kV and Contact ± 6kV		Perf. Criteria A
Radiated immunity	EN61000-4-3	20 V/m		Perf. Criteria A
Fast transient	EN61000-4-4	± 2kV		Perf. Criteria A
Surge	EN61000-4-5	DM ± 1kV and CM ± 2kV		Perf. Criteria A
Conducted immunity	EN61000-4-6	20 Vr.m.s		Perf. Criteria A
Power frequency magnetic field	EN61000-4-8	10 A/m		Perf. Criteria A
Dip and interruptions	EN60601-1-2	230VAC 50Hz	30% 500mS	Perf. Criteria A
			60% 100mS	Perf. Criteria A
			>95% 10mS	Perf. Criteria A
		100VAC 50Hz	>95% 5000mS	Perf. Criteria B
			30% 500mS	Perf. Criteria A
			60% 100mS	Perf. Criteria B
>95% 10mS	Perf. Criteria A			
>95% 5000mS	Perf. Criteria B			

**CHARACTERISTIC CURVE**

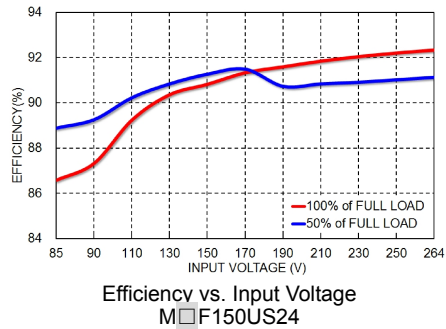
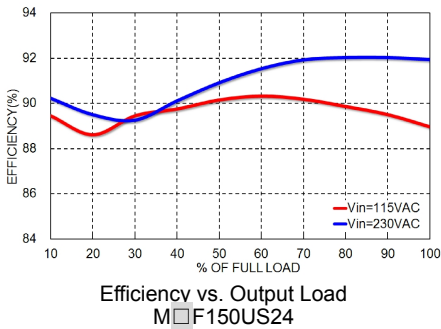
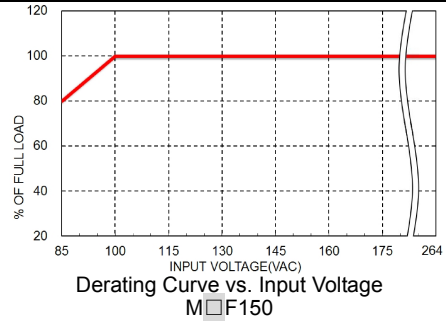
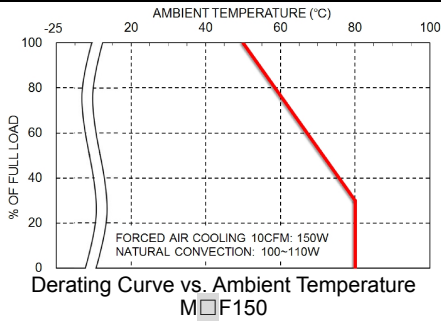

**MECHANICAL DRAWING**

**MAF** Open type

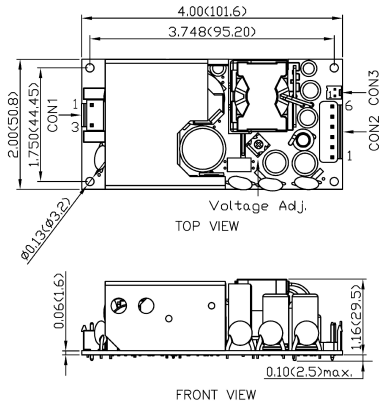

**MDF** Din rail type

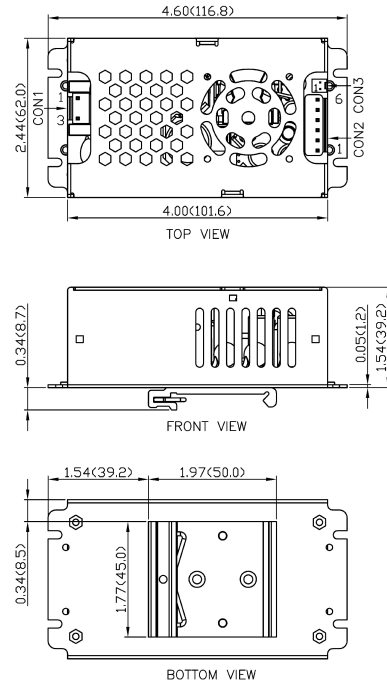

**MEF** Enclosed type

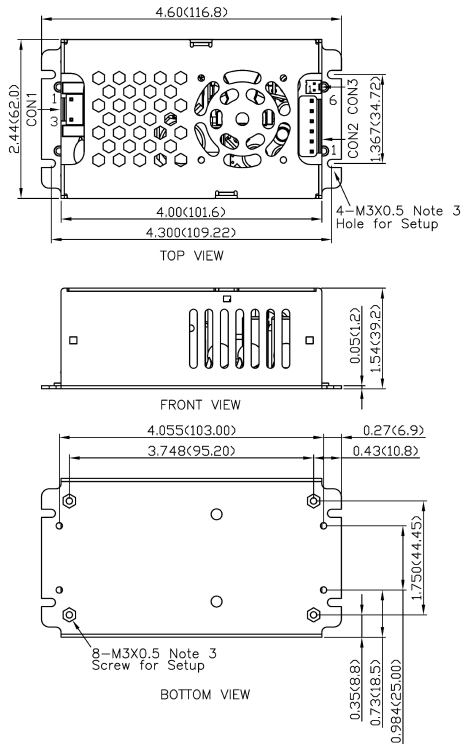

**MUF** U chassis type

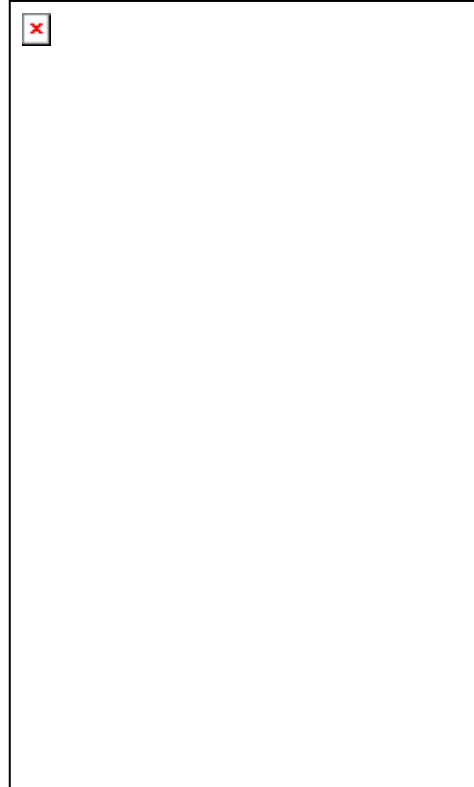

1. All dimensions in inch (mm)
2. Tolerance : x.xx±0.02 (x.x±0.5) x.xxx±0.01 (x.xx±0.25)
3. M3×0.5 screw locked torque MAX 5Kgf.cm/0.49N.m

**CONNECTORS CONNECTIONS**

CON1 – Input Connector	
Pin 1	Line
Pin 3	Neutral

CON2 – Output Connector	
Pin 1,2,3	-Vout
Pin 4,5,6	+Vout

CON3 – Fan Connector	
Pin 1	-Fan
Pin 2	+Fan

Mates with  
 JST housing : **VHR-3N**  
 JST crimp terminals : **SVH-21T-P1.1**

Mates with  
 JST housing : **VHR-6N**  
 JST crimp terminals : **SVH-21T-P1.1**

Mates with  
 Molex housing : **22-01-1022**  
 Molex crimp terminals : **2759**

Mounting holes marked with must be connected to safety earth for CLASS I application

**MECHANICAL DRAWING (CONTINUED)**

**MEF -E** Enclosed type with FAN



**MDF -E** Din rail type with FAN

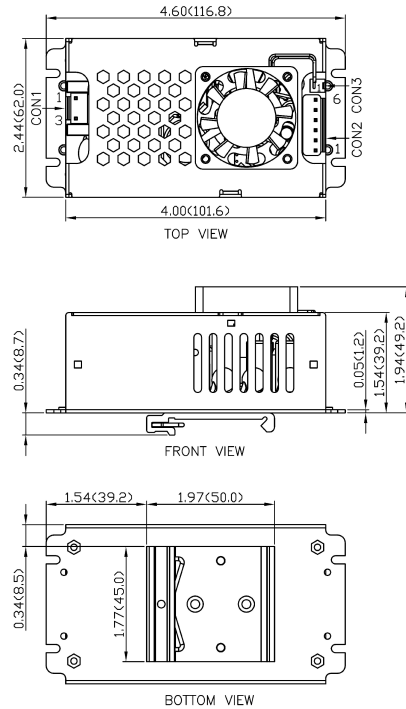

1. All dimensions in inch (mm)
2. Tolerance : x.xx±0.02 (x.x±0.5) x.xxx±0.01 (x.xx±0.25)
3. M3×0.5 screw locked torque MAX 5Kgf.cm/0.49N.m

**CONNECTORS CONNECTIONS**

**CON1 – Input Connector**

Pin 1	Line
Pin 3	Neutral

Mates with  
JST housing : **VHR-3N**  
JST crimp terminals : **SVH-21T-P1.1**

Mounting holes marked with ⊕  
must be connected to safety earth for CLASS I application

**CON2 – Output Connector**

Pin 1,2,3	-Vout
Pin 4,5,6	+Vout

Mates with  
JST housing : **VHR-6N**  
JST crimp terminals : **SVH-21T-P1.1**

**CON3 – Fan Connector**

Pin 1	-Fan
Pin 2	+Fan

Mates with  
Molex housing : **22-01-1022**  
Molex crimp terminals : **2759**