

### 1W, FIXED INPUT, ISOLATED DUAL OUTPUT SMD DC-DC CONVERTER

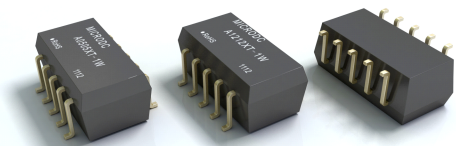

## FEATURES

- ◆Footprint over pins 1.64cm<sup>2</sup>
- ◆Short Circuit Protection(automatic recovery)
- ◆I/O isolation voltage 1000VDC
- ◆Operating Temperature: -40℃ ~ + 85℃
- ◆High efficiency up to 78%
- ◆Toroidal magnetics
- ◆Small SMD package with footprint
- ◆Power density 1.36W/cm<sup>3</sup>
- ◆Lead frame technology
- ◆Multi-layer ceramic capacitors
- ◆Custom solutions available

## MODEL SELECTION

A<sup>①</sup>05<sup>②</sup>05<sup>③</sup>X<sup>④</sup>T<sup>⑤</sup>-1W<sup>⑥</sup>

- ① Product Series
- ② Input Voltage
- ③ Output Voltage
- ④ Fixed Input
- ⑤ SMD Package
- ⑥ Rated Power

## APPLICATIONS

The A-XT-1W series are miniature,1W DC/DC converters with high isolation in a SMD package. With a new package design these converters are qualified for the higher temperatures requested by lead-free reflow solder processes. With the small footprint, these converters are the ideal solution for board level power distribution,mainly for applications in the industrial and telecom field. For automated SMD production lines the devices can be supplied in standard tape and reel package.



## SELECTION GUIDE

Order code	Input		Output		Efficiency (%.Typ.)	Isolation Capacitance pF	MTTF <sup>1</sup> KHrs
	Voltage(VDC)	Current (mA)	Voltage (VDC)	Current (mA)			
	Nominal	Rated Load					
A0303XT-1W	3.3	402	±3.3	±152	81	29	1005
A0305XT-1W	3.3	388	±5	±100	83	30	399
A0309XT-1W	3.3	405	±9	±55	74	34	827
A0312XT-1W	3.3	390	±12	±42	76	40	375
A0315XT-1W	3.3	392	±15	±33	81	42	206
A0503XT-1W	5	259	±3.3	±152	85	31	964
A0505XT-1W	5	290	±5	±100	83	33	1697
A0505NXT-1W	5	251	±5	±100	86	42	367
A0509XT-1W	5	267	±9	±55	85	38	682
A0512XT-1W	5	260	±12	±42	74	44	343
A0515XT-1W	5	256	±15	±33	78	43	188
A1205XT-1W	12	121	±5	±100	80	50	559
A1209XT-1W	12	113	±9	±55	80	72	375
A1212XT-1W	12	111	±12	±42	85	89	243
A1215XT-1W	12	110	±15	±33	81	100	154

1. Calculated using MIL-HDBK-217F with nominal input voltage at full load.  
All specifications typical at TA=25℃, nominal input voltage and rated output current unless otherwise specified.

## Input Characteristics

Parameter	Conditions	Min.	Typ.	Max.	Units
Voltage range	Continuous operation, 3V input	2.97	3.3	3.63	VDC
	Continuous operation, 5V input	4.5	5	5.5	VDC
	Continuous operation, 12V input	10.8	12	13.2	VDC
Start up time			41	50	mA p-p

## Isolation Characteristics

Parameter	Conditions	Min.	Typ.	Max.	Units
Isolation voltage	Flash tested for 1 second	1000			VDC
Resistance	Viso= 1000VDC	10			GΩ

## General Characteristics

Parameter	Conditions	Min.	Typ.	Max.	Units
Switching frequency	0312, 0315		100		kHz
	0303, 0305, 0503, 0505		110		kHz
	All other variants		115		kHz

## Absolute Maximum Ratings

Parameter	Conditions
Lead temperature 1.5mm from case for 10 seconds	300℃
Internal power dissipation	700mW
Input voltage V , A03 types	5.5V
Input voltage Vin, A05 types	7V
Input voltage Vin, A12 types	15V

Output Specifications					
Parameter	Conditions	Min.	Typ.	Max.	Units
Rated Power	TA=-40°C to 85°C	0.1		1.0	W
Voltage Set Point	See tolerance envelope				
Line regulation	High VIN to low VIN		1.0	1.2	%%
Load regulation <sup>1</sup>	10% load to rated load, 0303& 0503		10	15	%
	10% load to rated load, 5V output types		10	12	%
	10% load to rated load, 0309		9.0	10	%
	10% load to rated load, 0509 & 1209		6.5	8.0	%
	10% load to rated load, 0312 & 0315		11	14	%
	10% load to rated load, 0512 & 1212		6.0	8.5	%
Ripple& Noise	10% load to rated load, 0515 & 1215		6.0	7.0	%
	BW=DC to 20MHz, 3.3V output types, A0305 & A0505		40	80	mV p-p
	BW=DC to 20MHz, all other 5V output types		50	100	mV p-p
	BW=DC to 20MHz, 9V output types		35	80	mV p-p
	BW=DC to 20MHz, 12V output types		50	110	mV p-p
	BW=DC to 20MHz, 15V output types		65	110	mV p-p

Note:1、 12V input types have typically 3% less load regulation change.

Temperature Characteristics					
Parameter	Conditions	Min.	Typ.	Max.	Units
Specification	All output types	-40		85	°C
Storage		-55		125	°C
Case temperature rise above ambient	0305, 0505, 0312, 0315		19		°C
	0303, 0309, 0503		25		°C
	0505, 1205		46		°C
	All other variants		35		°C
Cooling	Free air convection				

### Technical notes

**ISOLATION VOLTAGE**  
 'Hi Pot Test', 'Flash Tested', 'Withstand Voltage', 'Proof Voltage', 'Dielectric Withstand Voltage' & 'Isolation Test Voltage' are all terms that relate to the same thing, a test voltage, applied for a specified time, across a component designed to provide electrical isolation, to verify the integrity of that isolation.  
 Professional Power Module A-XT-1W series of DC/DC converters are all 100% production tested at their stated isolation voltage. This is 1kVDC for 1 second.  
 A question commonly asked is, "What is the continuous voltage that can be applied across the part in normal operation?"  
 For a part holding no specific agency approvals, such as the A-XT-1W series, both input and output should normally be maintained within SELV limits i.e. less than 42.4V peak, or 60VDC. The isolation test voltage represents a measure of immunity to transient voltages and the part should never be used as an element of a safety isolation system. The part could be expected to function correctly with several hundred volts offset applied continuously across the isolation barrier; but then the circuitry on both sides of the barrier must be regarded as operating at an unsafe voltage and further isolation/insulation systems must form a barrier between these circuits and any user-accessible circuitry according to safety standard requirements.

**REPEATED HIGH-VOLTAGE ISOLATION TESTING**  
 It is well known that repeated high-voltage isolation testing of a barrier component can actually degrade isolation capability, to a lesser or greater degree depending on materials, construction and environment. The A-XT-1W series has toroidal isolation transformers, with no additional insulation between primary and secondary windings of enameled wire. While parts can be expected to withstand several times the stated test voltage, the isolation capability does depend on the wire insulation. Any material, including this enamel (typically polyurethane) is susceptible to eventual chemical degradation when subject to very high applied voltages thus implying that the number of tests should be strictly limited. We therefore strongly advise against repeated high voltage isolation testing, but if it is absolutely required, that the voltage be reduced by 20% from specified test voltage.  
 This consideration equally applies to agency recognized parts rated for better than functional isolation where the wire enamel insulation is always supplemented by a further insulation system of physical spacing or barriers.

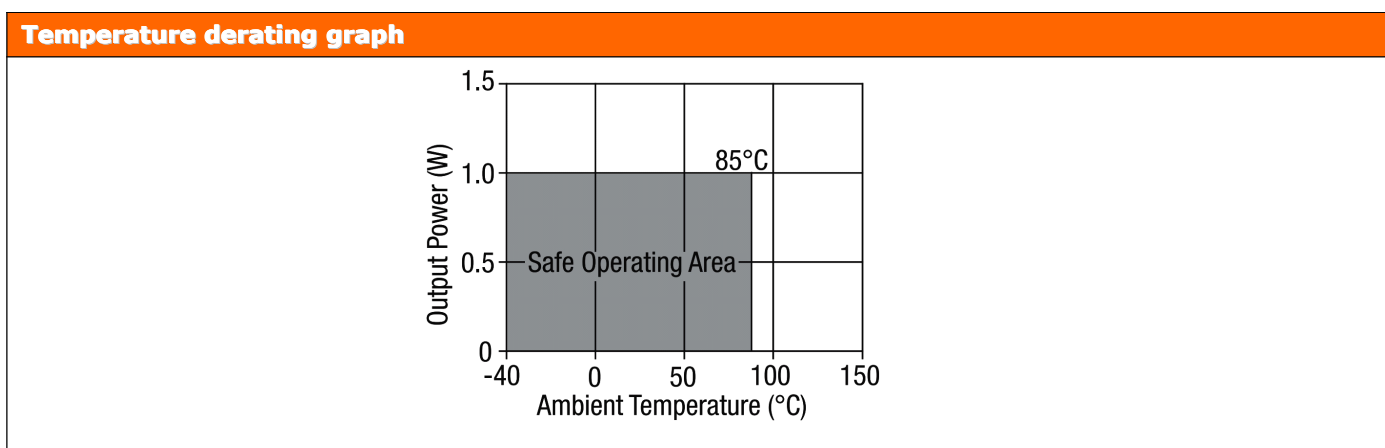

### Application Notes

#### Minimum load

The minimum load to meet datasheet specification is 10% of the full rated load across the specified input voltage range. Lower than 10% minimum loading will result in an increase in output voltage, which may rise to typically double the specified output voltage if the output load falls to less than 5%.

#### Capacitive loading and start up

Typical start up times for this series, with a typical input voltage rise time of 2.2  $\mu$ s and output capacitance of 10  $\mu$ F, are shown in the table below. The product series will start into a capacitance of 47  $\mu$ F with an increased start time, however, the maximum recommended output capacitance is 10  $\mu$ F.

Start-up time		Start-up time	
$\mu$ s		$\mu$ s	
A0303XT	1630	A0509XT	6850
A0305XT	1359	A0512XT	11560
A0309XT	3435	A0515XT	15640
A0312XT	6590	A1205XT	1154
A0315XT	25340	A1209XT	4050
A0503XT	1599	A1212XT	7995
A0505XT	2185	A1215XT	11200
A0305NXT	1395		

Typical Start-Up Wave Form

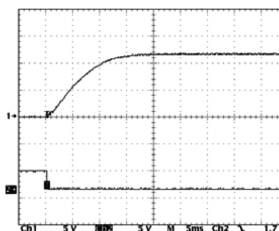

#### Ripple & Noise Characterisation Method

Ripple and noise measurements are performed with the following test configuration.

C1	1 $\mu$ F X7R multilayer ceramic capacitor, voltage rating to be a minimum of 3 times the output voltage of the DC/DC converter
C2	10 $\mu$ F tantalum capacitor, voltage rating to be a minimum of 1.5 times the output voltage of the DC/DC converter with an ESR of less than 100m $\Omega$ at 100 kHz
C3	100nF multilayer ceramic capacitor, general purpose
R1	450 $\Omega$ resistor, carbon film, $\pm$ 1% tolerance
R2	50 $\Omega$ BNC termination
T1	3T of the coax cable through a ferrite toroid
RLOAD	Resistive load to the maximum power rating of the DC/DC converter. Connections should be made via twisted wires

Measured values are multiplied by 10 to obtain the specified values.

#### Differential Mode Noise Test Schematic

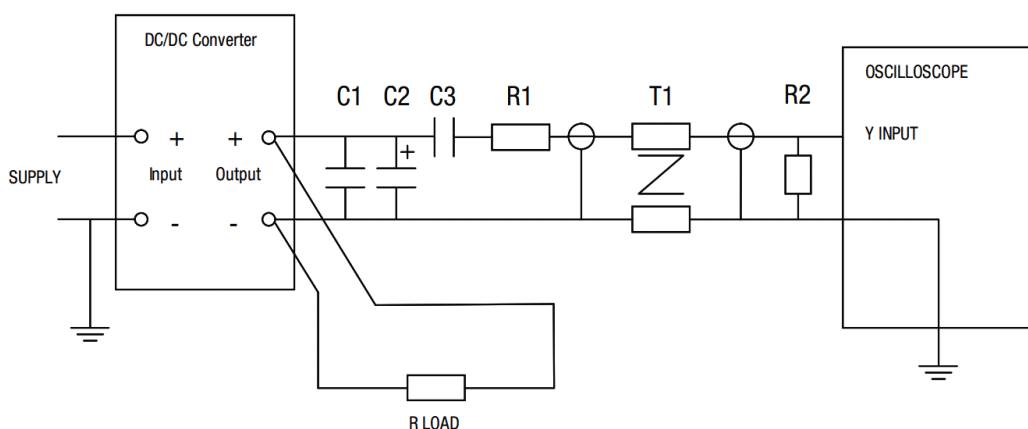

### Application Notes

#### Output Ripple Reduction

By using the values of inductance and capacitance stated, the output ripple at the rated load is lowered to 5mV p-p max.

##### Component selection

**Capacitor:** It is required that the ESR (Equivalent Series Resistance) should be as low as possible, ceramic types are recommended.

The voltage rating should be at least twice (except for 15V output), the rated output voltage of the DC/DC converter.

**Inductor:** The rated current of the inductor should not be less than that of the output of the DC/DC converter. At the rated current, the DC resistance of the inductor should be such that the voltage drop across the inductor is <2% of the rated voltage of the DC/DC converter. The SRF (Self Resonant Frequency) should be >20MHz.

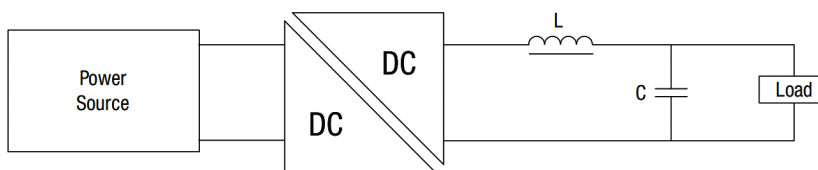

	Inductor			Capacitor
	L, $\mu$ H	SMD	Through Hole	C, $\mu$ F
A0303XT	10	82103C	11R103C	4.7
A0305XT	22	82223C	11R223C	2.2
A0309XT	22	82223C	11R223C	2.2
A0312XT	47	82473C	11R473C	1
A0315XT	220	82474C	11R474C	0.22
A0503XT	10	82103C	11R103C	4.7
A0505XT	10	82103C	11R103C	4.7
A0305NXT	10	82103C	11R103C	4.7
A0509XT	22	82223C	11R103C	2.2
A0512XT	47	82473C	11R223C	1
A0515XT	220	82474C	11R473C	0.22
A1205XT	10	82103C	11R474C	4.7
A1209XT	22	82223C	11R223C	2.2
A1212XT	47	82473C	11R473C	1
A1215XT	220	82474C	11R474C	0.22

### Tolerance Envelopes

Tolerance Envelope - 3.3V output types.

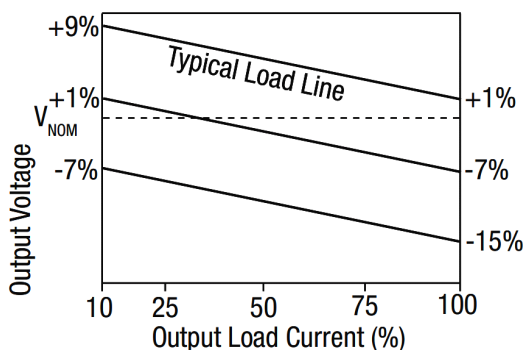

All other types.

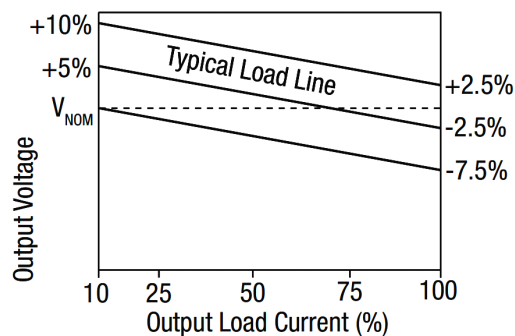

The voltage tolerance envelope shows typical load regulation characteristics for this product series. The tolerance envelope is the maximum output voltage variation due to changes in output loading.

### OUTLINE DIMENSIONS & FOOTPRINT DETAILS

#### MECHANICAL DIMENSIONS

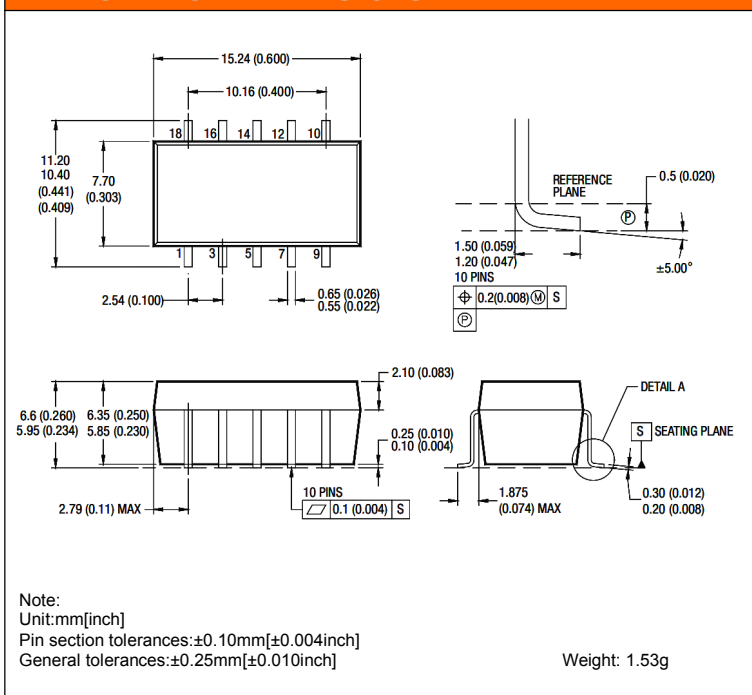

#### SOLDER PAD DIMENSION

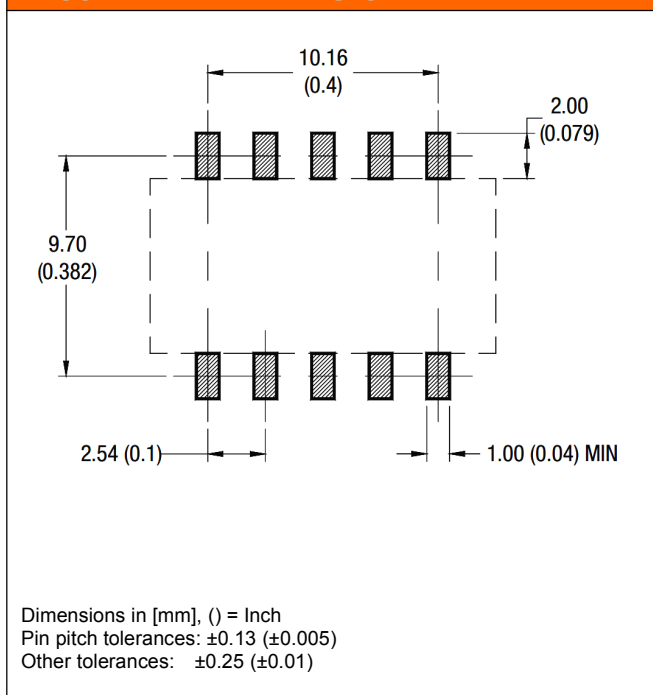

#### FOOTPRINT DETAILS

Pin	Dual
1	-Vin
3	+Vin
5	NA
7	0V
9	-Vout
10	NA
12	+Vout
14	NA
16	NA
18	NA

NA - Not available for electrical connection.

#### TUBE OUTLINE DIMENSIONS

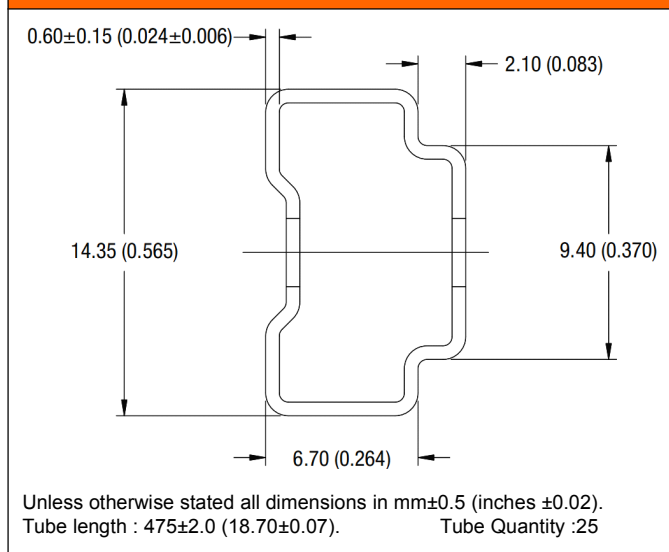

**Specifications can be changed any time without notice.**

**No parallel connection or plug and play.**

Note:

1. The load shouldn't be less than 10%, otherwise ripple will increase dramatically.
2. Operation under 10% load will not damage the converter; However, they may not meet all specification listed.
3. All specifications measured at Ta=25°C, humidity<75%, nominal input voltage and rated output load unless otherwise specified.
4. In this datasheet, all the test methods of indications are based on corporate standards.
5. Only typical models listed, other models may be different, please contact our technical person for more details.

**Tape & Reel Specifications**

**Reel Packaging Details**

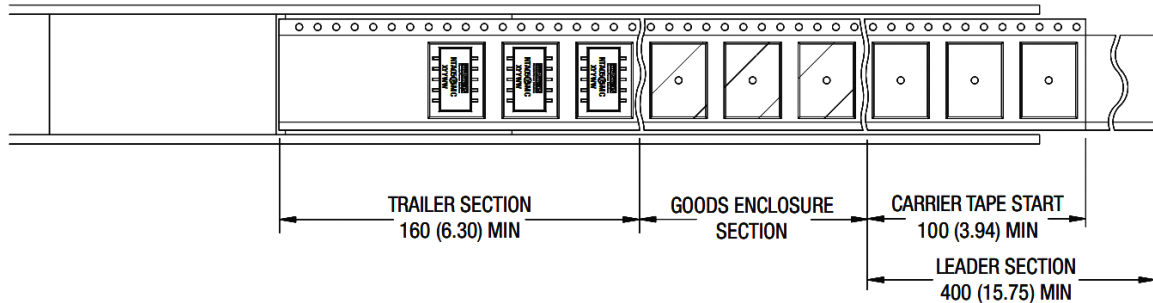

**Product Orientation**

Pin 1, located nearest to carrier drive sprocket.

Reel Quantity : 500

**Reel Outline Dimensions**

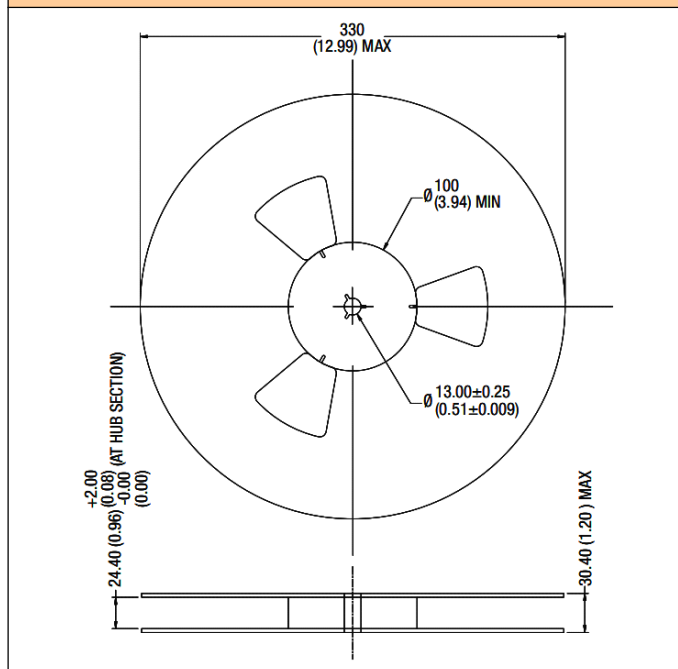

**Tape Outline Dimensions**

